

FPZ670

Flat Panel Display Stand

For up to 90" Displays

The Peerless-AV® FPZ-670 display stand is designed to support up to two 90" displays mounted back-to-back in either landscape or portrait orientation. The attractive, yet robust and functional, stand is ideal for a wide variety of applications and settings from boardrooms, training rooms and lobbies to classrooms, auditoriums or exhibition halls. Its appearance is complemented by a sturdy base with a concealed compartment to house media players and surge protectors while its internal cable management system conceals cables and cords, delivering a clean look for any application.



Display size: up to 90"



Max load: 400lb (181.4kg) total
200lb (90.7kg) per display
up to two displays

FEATURES

- Fits single or back-to-back mounted displays up to 90"
- VESA® 200 x 200mm compatible. Additional display mounting patterns supported by optional PLP display adaptor plate (sold separately)
- Enclosure built into base is designed to conceal and protect media players
- Continuous vertical adjustment on 6' (1.83m) columns for perfect viewing height
- Hook-on design for quick and simple installation
- Integrated cable management protects, contains and conceals cables for a clean, professional installation
- Portrait or landscape orientation



SINGLE OR BACK-TO-BACK

Multiple configurations for displays up to 90"

INTEGRATED CABLE MANAGEMENT

Protects, contains and conceals cables for a clean, professional installation



HEIGHT ADJUSTMENT

Ideal display position along the 6' (1.83m) columns

MEDIA PLAYER STORAGE

Designed to conceal media player and surge protectors



cUL US
Pending

RoHS

MADE IN USA

CLICK: peerless-av.com

CALL: 800.865.2112

FAX: 800.359.6500

peerless-AV®

FPZ670	Flat Panel Display Stand for up to 90" Displays
---------------	---

Product Specifications

	DIMENSIONS (W x H x D)	PRODUCT WEIGHT	LOAD CAPACITY	FINISH	AVAILABLE COLORS
FPZ670	39.94" x 72.33" x 48" (1015 x 1837 x 1219mm)	194.4lb (88.1kg)	400lb (181.4kg) total 200lb (90.7kg) per display up to two displays	Powder Coat	Black

Package Specifications

	PACKAGE SIZE (W x H x D)	PACKAGE SHIP WEIGHT	PACKAGE UPC CODE	PACKAGE CONTENTS	UNITS IN PACKAGE
FPZ670	Box 1: 50" x 8.75" x 41.625" (1270 x 222 x 1057mm) Box 2 & 3: 72" x 4" x 4" (1830 x 101 x 101mm)	Box 1: 167.5lb (76.1kg) Box 2 & 3: 17.6lb (7.9kg)	735029257844	Base, base cover, 2 columns, VESA® 200 x 200mm adaptor plates & mounting hardware	1

Accessories

PLP-UNL:	Universal Adaptor Plate
MIS735:	Dual-Display Cartridge

All dimensions = inch (mm)

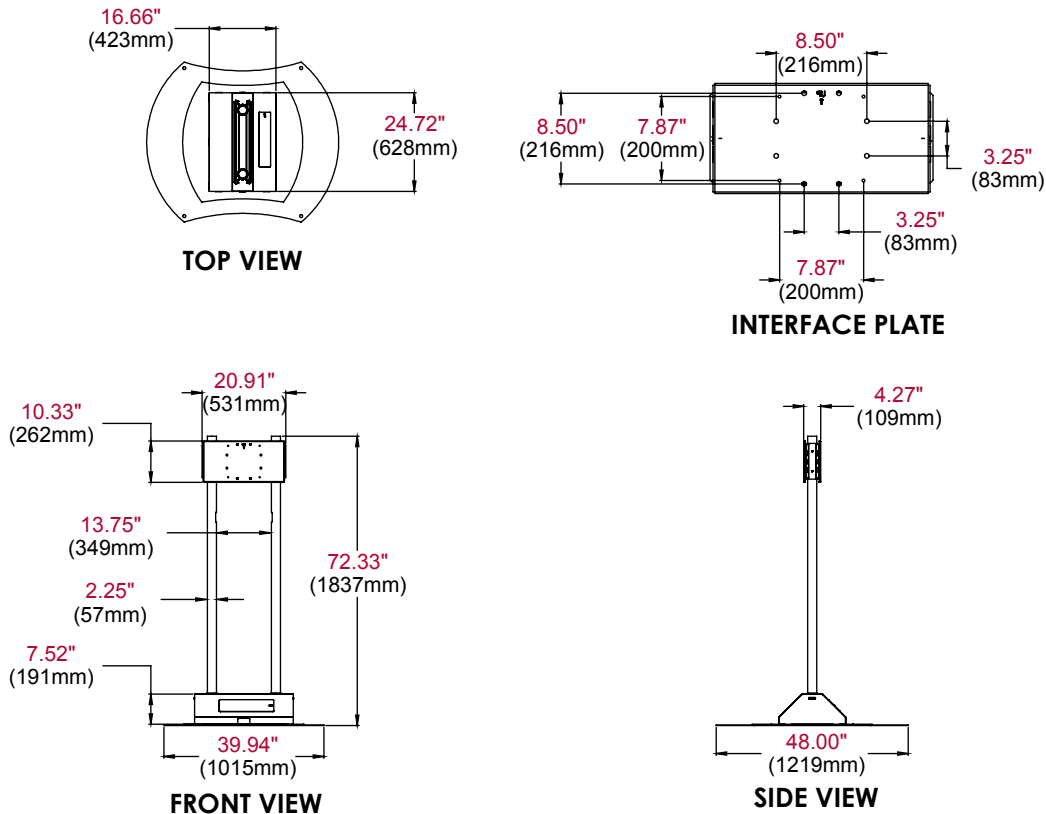

ARCHITECTS SPECIFICATIONS

The Floor Cart shall be a Peerless-AV model FPZ670 and shall be installed where indicated on the plans. It shall be constructed of heavy gauge cold rolled steel. Assembly and installation shall be done according to instructions provided by the manufacturer.